

SONY®

デジタルゲージ / Digital Gauge / Digitale Meßtaster

DG10B / DG25B Series

DG10BNM / DG10BPM / DG10BSM

DG25BNM / DG25BPM / DG25BLM / DG25BSM

DG10BNE / DG10BPE / DG10BSE

DG25BNE / DG25BPE / DG25BLE / DG25BSE

お買い上げいただき、ありがとうございます。

ご使用前に、この取扱説明書を必ずお読みください。

ご使用に際しては、この取扱説明書どおりお使いください。

お読みになった後は、後日お役に立つこともございますので、必ず保管してください。

Read all the instructions in the manual carefully before use and strictly follow them.
Keep the manual for future references.

Lesen Sie die ganze Anleitung vor dem Betrieb aufmerksam durch und folgen Sie beim Betrieb des Geräts den Anweisungen. Bewahren Sie diese Bedienungsanleitung zum späteren Nachlesen griffbereit auf.

取扱説明書 / Instruction Manual / Bedienungsanleitung
第1版 / 1st Edition / 1.Auflage

[For U.S.A. and Canada]

THIS CLASS A DIGITAL DEVICE COMPLIES WITH PART15 OF THE FCC RULES AND THE CANADIAN ICES-003. OPERATION IS SUBJECT TO THE FOLLOWING TWO CONDITIONS.

- (1) THIS DEVICE MAY NOT CAUSE HARMFUL INTERFERENCE, AND
- (2) THIS DEVICE MUST ACCEPT ANY INTERFERENCE RECEIVED, INCLUDING INTERFERENCE THAT MAY CAUSE UNDERSIGNED OPERATION.

CET APPAREIL NUMERIQUE DE LA CLASSE A EST CONFORME A LA NORME NMB-003 DU CANADA.

[For EU and EFTA countries]

CE Notice

Making by the symbol CE indicates compliance of the EMC directive of the European Community. Such marking is indicative meets or exceeds the following technical standards.

EN 55011 Group 1 Class A / 91 :

"Limits and methods of measurement of electromagnetic disturbance characteristics of industrial, scientific and medical (ISM) radio-frequency equipment"

EN 50082-2 / 95:

"Electromagnetic compatibility - Generic immunity standard Part 2 : Industrial environment"

警告

本装置を機械指令 (EN 60204-1) の適合を受ける機器にご使用の場合は、その規格に適合するように方策を講じてから、ご使用ください。

Warning

When using this device with equipment governed by Machine Directives EN 60204-1, measures should be taken to ensure conformance with those directives.

Warnung

Wenn dieses Gerät mit Ausrüstungsteilen verwendet wird, die von den Maschinenrichtlinien EN 60204-1 geregelt werden, müssen Maßnahmen ergriffen werden, um eine Übereinstimmung mit diesen Normen zu gewährleisten.

Safety Precautions

Sony Precision Technology products are designed in full consideration of safety. However, improper handling during operation or installation is dangerous and may lead to fire, electric shock or other accidents resulting in serious injury or death. In addition, these actions may also worsen machine performance.

Therefore, be sure to observe the following safety precautions in order to prevent these types of accidents, and to read these “Safety Precautions” before operating, installing, maintaining, inspecting, repairing or otherwise working on this unit.

Warning Indication Meanings

The following indications are used throughout this manual, and their contents should be understood before reading the text.



Warning

Failure to observe these precautions may lead to fire, electric shock or other accidents resulting in serious injury or death.



Caution

Failure to observe these precautions may lead to electric shock or other accidents resulting in injury or damage to surrounding objects.

Symbols requiring attention



Symbols prohibiting actions



DO NOT
DISASSEMBLE



Warning Failing to follow the precaution items given below may lead to severe injury or death.



• Do not damage, modify, excessively bend, pull on, place heavy objects on or heat the cable, as this may damage the cable and result in fire or electric shock.



• Do not disassemble or modify the unit, as this may result in injury or electric shock. These actions may also damage the internal circuitry.



Caution Failing to follow the precaution items given below may lead to injury or damage to surrounding objects.



• The unit does not have an explosion-proof structure. Therefore, do not use the unit in an atmosphere charged with inflammable gases as this may result in fire.

General precautions

When using Sony Precision Technology products, observe the following general precautions along with those given specifically in this manual to ensure proper use of the products.

- Before and during operations, be sure to check that our products function properly.
- Provide adequate safety measures to prevent damages in case our products should develop malfunctions.
- Use outside indicated specifications or purposes and modification of our products will void any warranty of the functions and performance as specified of our products.
- When using our products in combination with other equipment, the functions and performances as noted in this manual may not be attained, depending on operating and environmental conditions.

Contents

1. Operating Cautions	1
2. Mounting Instructions	2
3. Names of parts	3
4. Specifications	4
5. Optional Accessories	7
6. Interpolation Box	8
6-1. Resolution and Directivity Setting Method	8
6-2. Output Signal	11
6-2-1. Output Signal Phase Difference	11
6-2-2. Output Signal Alarm	11
6-3. Output Connectors	12
6-4. Output Cable	13
7. Outside Dimensions	15

1. Operating Cautions

- Do not use the unit in places where it may receive excessive shocks. Otherwise the inside of the unit may be damaged or the unit may become unable to produce normal output signals.
- Be sure to turn off the power before connecting or disconnecting connectors in order to prevent damage or misoperation.
- Locate the probe at least 10 cm/3.94" away from a strong magnetic source.
- Do not pull the cable when mounting or demounting the probe, or the cable may be disconnected.
- The probe is electrically shorted to the display unit ground through the shielded wire of the cable. When you mount the probe on machine tools, be sure to ground the machine tools.
- The N, L series spindle is not protectively sealed. It is designed for use with machines in clean environments and in testing rooms. Do not expose the N, L series spindle to chips and cutting oil.
- The P, S series probe has a dustproof, drip-proof, and oil-resistant structure that can withstand exposure to chips, cutting oil, and machine oil. However, do not immerse it entirely in oil or cutting oil as it does not have a waterproof structure.
- Adhesion of foreign objects, such as cutting oil which increases in viscosity after drying, may hinder accurate spindle motion.
After you wash the spindle, apply a coat of machine oil to it.
- Nitrile butadiene rubber material is used for dripproof and dustproof sealing of the P, S series spindle's rubbing surface. The spindle's smooth motion could be lost if the lubricant is removed from its surface through exposure to cutting oil and water.

2. Mounting Instructions

- Use a mounting holder with dimensions as shown in Fig. 2 to install the measuring probe. Tighten the clamp to hold the stem to a torque of about 4 N•m (See Fig. 2.). The stem is hardened by baking but an excessive tightening may damage the inner ball bearing and the spindle and the smooth spindle motion may be lost. Be careful about this when using another mounting holder than shown. Do not hold the stem directly with screws.
- Use of a nominal 2.5 spring washer is recommended to prevent loosening of the feeler. However, the spring washer does not need to be used for flat feelers.
- Since the mounting parallelism affects measuring accuracy, adjust the parallelism to within 0.3 mm (0.01") for a movement of 100 mm (3.94") using the mounting bracket (or sleeve).
- To prevent the cable from breaking, fix it in a suitable position. Never handle the cable by forcibly pulling or bending it. (Inside bend radius 40 mm or more)
- Optional DZ-191 coupling is available to mount the probe on a machine.

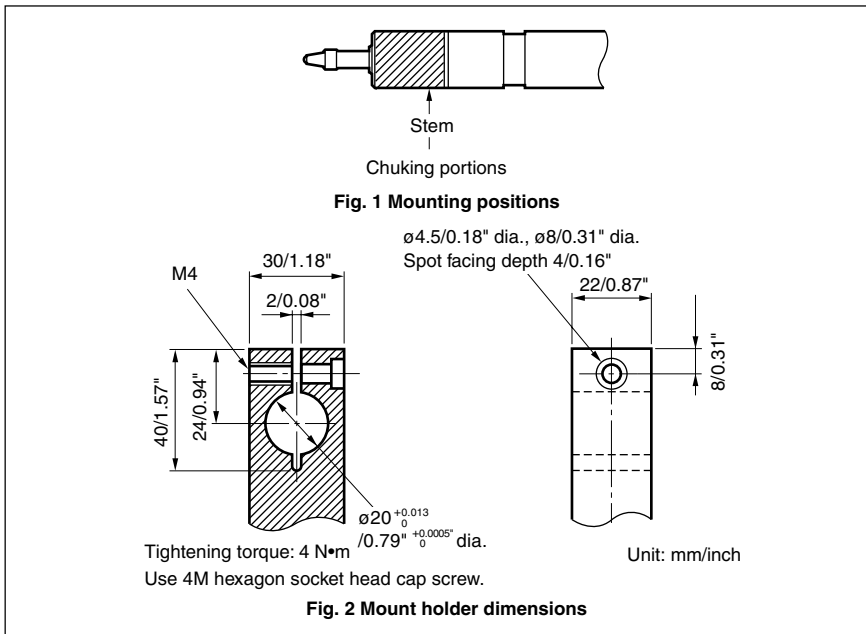

3. Names of parts

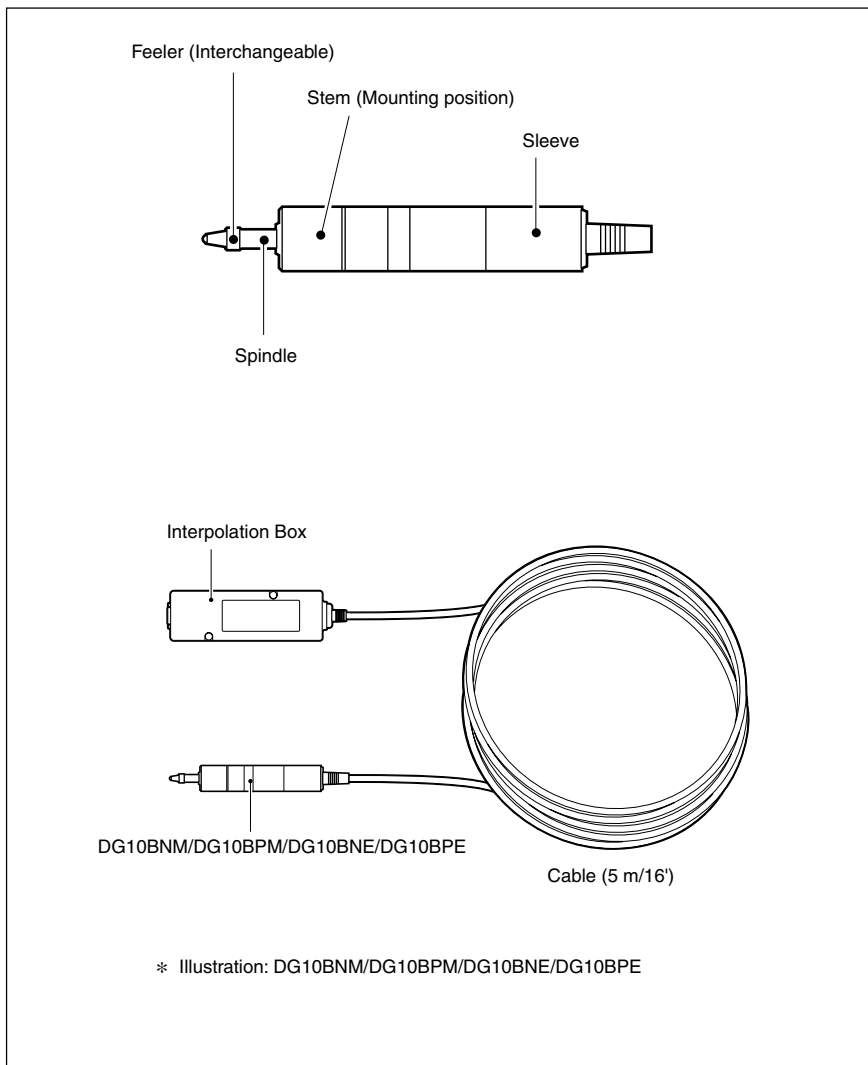

4. Specifications

Model Item	DG10BNM	DG10BNE	DG10BPM	DG10BPE	DG10BSM	DG10BSE
Measuring range	0 to 10 mm/ 0 to 0.39"					
Resolution	0.0005, 0.001, 0.002, 0.005, 0.01 mm					
Accuracy	0.002 mm/ 0.00008"					
Maximum response speed	1 m/s					
Measuring force Downward Horizontal Upward	0.8 ± 0.35 N 0.6 ± 0.3 N 0.3 ± 0.25 N		4.9 N or less			
Feeler	Provided with a carbide ball tip DZ-122 (Mount screw M2.5)					
Dia. of Stem	ø20 ⁰ _{-0.013} mm/0.79" ⁰ _{-0.0005} " dia.					
Cable length	5 m/16'					
Operating temperature	0 °C to 50 °C /32 °F to 122 °F (Interpolation box: 0 °C to 40 °C/ 32 °F to 104 °F)					
Storage temperature	-20 °C to 60 °C /-4 °F to 140 °F					
Dimensions	ø20×122 mm/0.79" dia.×4.80"				ø20×103 mm /0.79" dia.×4.06"	
Mass	Approx. 230 g /8.11 oz					
Seal	Nil		Plovided			
Power supply voltage	DC 5 V ±5%	DC 11 to 28 V	DC 5 V ±5%	DC 11 to 28 V	DC 5 V ±5%	DC 11 to 28 V
Power consumption	300 mA	150 mA	300 mA	150 mA	300 mA	150 mA
Output signal	A/B phase signal complying with EIA-422 (Line driver: AM26C31 or equivalent)					
Minimum phase difference	200 ns (at maximum response speed)					

Note

- Accuracy and measuring forces given above are those obtained at 20 °C/ 68 °F.
- The mass indicated is the total mass excluding the cable and interpolation box.

Item	Model	DG25BNM	DG25BNE	DG25BPM	DG25BPE
Measuring range		0 to 25 mm/ 0 to 0.98"			
Resolution		0.0005, 0.001, 0.002, 0.005, 0.01 mm			
Accuracy		0.002 mm/ 0.00008"			
Maximum response speed		1 m/s			
Measuring force					
Downward		1 ±0.4 N		4.9 N or less	
Horizontal		0.7 ±0.35 N			
Upward		0.4 ±0.3 N			
Feeler		Provided with a carbide ball tip DZ-122 (Mount screw M2.5)			
Dia. of Stem		ø20 ⁰ _{-0.013} mm/0.79 ⁰ _{-0.0005} " dia.			
Cable length		5 m/16'			
Operating temperature		0 °C to 50 °C /32 °F to 122 °F (Interpolation box: 0 °C to 40 °C/ 32 °F to 104 °F)			
Storage temperature		-20 °C to 60 °C /-4 °F to 140 °F			
Dimensions		ø20×180 mm/0.79" dia.×7.09"			
Mass		Approx. 300 g /10.58 oz			
Seal		Nil		Provided	
Power supply voltage		DC 5 V ±5%	DC 11 to 28 V	DC 5 V ±5%	DC 11 to 28 V
Power consumption		300 mA	150 mA	300 mA	150 mA
Output signal		A/B phase signal complying with EIA-422 (Line driver: AM26C31 or equivalent)			
Minimum phase difference		200 ns (at maximum response speed)			

Note

- Accuracy and measuring forces given above are those obtained at 20 °C/ 68 °F.
- The mass indicated is the total mass excluding the cable and interpolation box.

Item	Model	DG25BLM	DG25BLE	DG25BSM	DG25BSE
Measuring range	0 to 25 mm/ 0 to 1.0"				
Resolution	0.0005, 0.001, 0.002, 0.005, 0.01 mm				
Accuracy	0.002 mm/ 0.00008"				
Maximum response speed	1 m/s				
Measuring force					
Downward	1 ±0.4 N		4.9 N or less		
Horizontal	0.7 ±0.35 N				
Upward	0.4 ±0.3 N				
Feeler	Provided with a carbide ball tip DZ-122 (Mount screw M2.5)				
Dia. of Stem	$\varnothing 20_{-0.013}^0$ mm/ $0.79_{-0.0005}^0$ dia.				
Cable length	5 m/16'				
Operating temperature	0 °C to 50 °C /32 °F to 122 °F (Interpolation box: 0 °C to 40 °C/ 32 °F to 104 °F)				
Storage temperature	-20 °C to 60 °C /-4 °F to 140 °F				
Dimensions	$\varnothing 20 \times 160$ mm/ 0.79 " dia. $\times 6.3$ "				
Mass	Approx. 300 g /10.58 oz				
Seal	Nil		Provided		
Power supply voltage	DC 5 V ±5%	DC 11 to 28 V	DC 5 V ±5%	DC 11 to 28 V	
Power consumption	300 mA	150 mA	300 mA	150 mA	
Output signal	A/B phase signal complying with EIA-422 (Line driver: AM26C31 or equivalent)				
Minimum phase difference	200 ns (at maximum response speed)				

Note

- Accuracy and measuring forces given above are those obtained at 20 °C/ 68 °F.
- The mass indicated is the total mass excluding the cable and interpolation box.

5. Optional Accessories

- DZ-100 Roller feeler
- DZ-161 Lift lever
- DZ-191 Coupling
- DZ-501 Ceramic surface plate gauge stand
 - Surface plate: size 110×110 mm /4.33×4.33"
 - Mass: 13 kg /28.7 lb
- DZ-531 Large stone surface plate gauge stand
 - Surface plate: size 350×350 mm /13.78"×13.78"
 - Mass: 38 kg /83.8 lb

6. Interpolation Box

Probe resolution and directivity are set with the switches inside the interpolation box.

6-1. Resolution and Directivity Setting Method

1 Cover Removal

Remove the two screws and remove the cover.

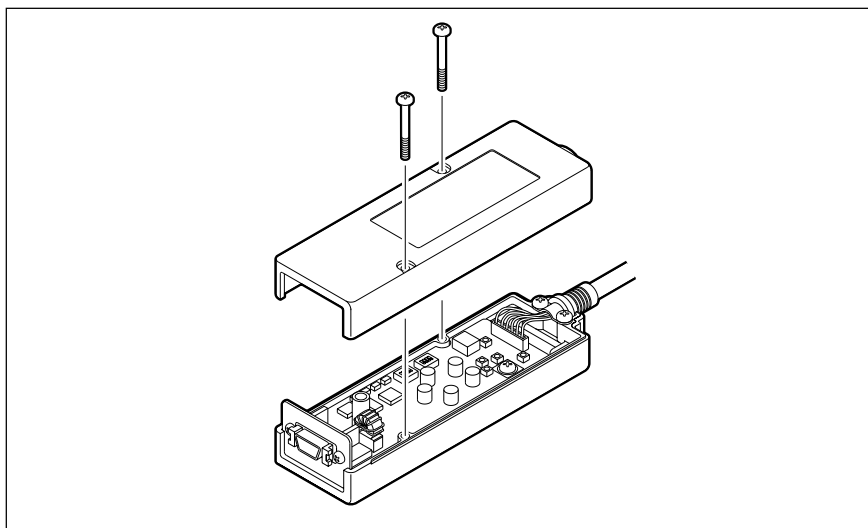

2 Switch Setting

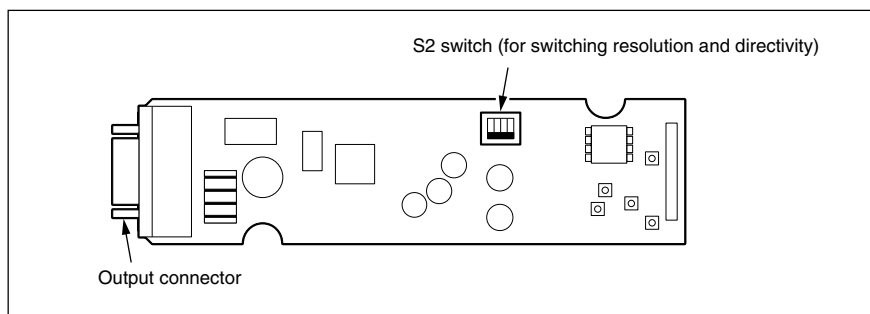

Note

Do not touch any parts other than the S2 switch when changing the switch setting.

Setting of Direction and Resolution Switching

The phase relationship of phases A and B and resolution for the direction of movement of the probe spindle can be switched with the S2 switch.

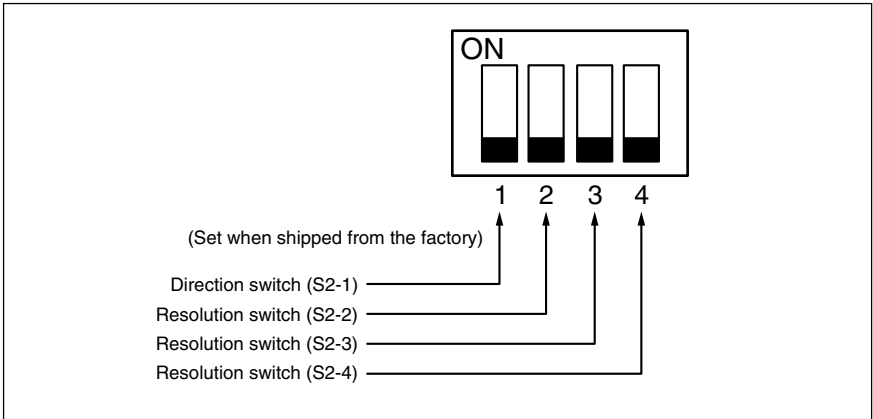

Switching of Direction

Directivity is switched with S2-1 (default setting: OFF).

S2-1

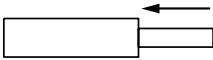

Moves the probe in the direction in which the spindle is pushed in.

ON

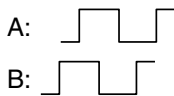

B phase signal advances.

OFF

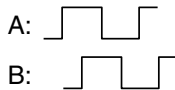

A phase signal advances.

Switching of Resolution

Resolution is switched with S2-2, S2-3 and S2-4 (default setting: all OFF).

Resolution switch (S2-2)	Resolution switch (S2-3)	Resolution switch (S2-4)	Resolution μm
OFF	OFF	OFF	0.5
OFF	ON	OFF	1
ON	ON	OFF	2
OFF	ON	ON	5
ON	ON	ON	10

* Combinations other than those shown in the table cannot be used.

The phase difference between phases A and B is taken to be the resolution.

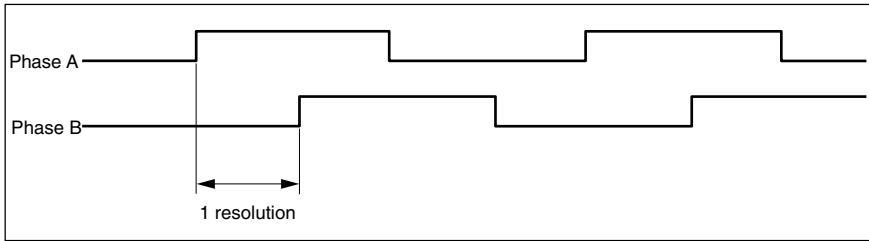

6-2. Output Signal

The signals output from the interpolation box are A and B phase signals in the form of a voltage differential output complying with EIA-422. Please confirm that the minimum input phase difference of the controller or counter connected to this probe is smaller than 200 ns prior to use.

6-2-1. Output Signal Phase Difference

Phases A and B output from the interpolation box are generated approximately every $20\ \mu\text{s}$. The phase A and B signals output from the interpolation box change depending on the speed of movement. The minimum phase difference between phases A and B is 200 ns.

When 0.025 m/s or less (at resolution of $0.5\ \mu\text{m}$)

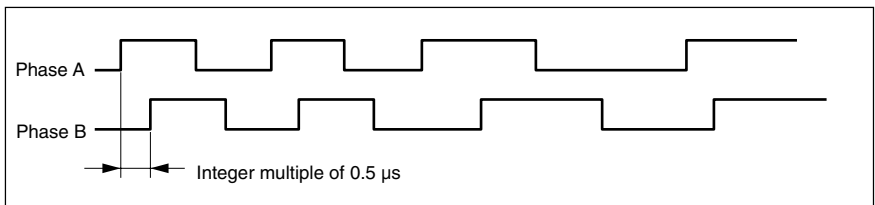

When 0.025 m/s or more (at resolution of $0.5\ \mu\text{m}$)

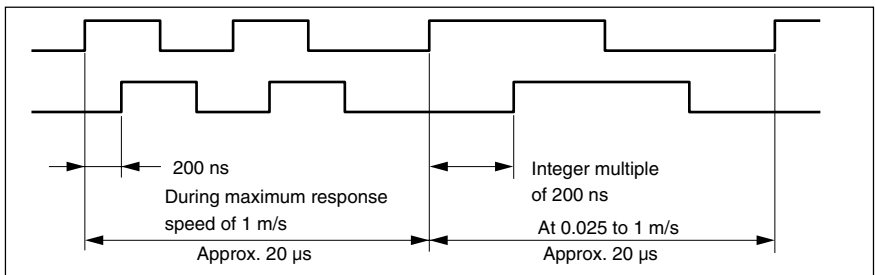

6-2-2. Output Signal Alarm

Phases A and B output by this probe turn to high impedance state when the response speed has been exceeded.

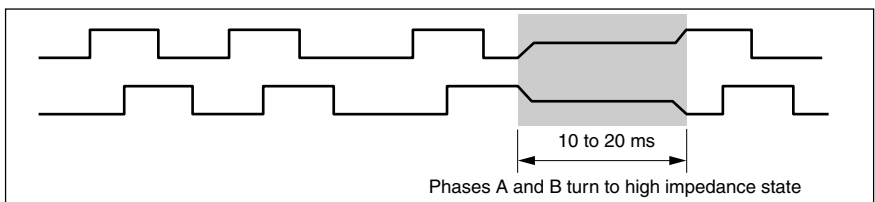

6-3. Output Connectors

Connectors used:

Receptacle: MDR 10214-52A2JL, Sumitomo 3M

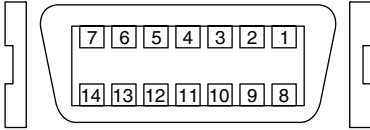

Recommended connector:
MDR 10114-3000VE,
Sumitomo 3M

Pin No.	Signal
1	PCA
2	*PCA
3	PCB
4	*PCB
5	Reserved
6	Reserved
7	FG (shield) (note)
8	Reserved
9	Reserved
10	Reserved
11	0 V
12	-S (0 V)
13	+S (+ V) (note)
14	+ V (note)

Note

FG (shield) is connected to the casing.

0 V and FG are insulated with a 0.2 μ F (250 V) capacitor.

Do not connect anything to the reserved pins.

The power supply (+V) is DC +5 V for model names ending in “M”, or DC +12 to 24 V for model names ending in “E”.

Pin No. 12 -S (0 V) and Pin No. 13 +S (+V) are for remote sensing.

6-4. Output Cable

Use a shielded cable as shown in the figure below for output signal. Connect the shielded wires of the cable to the case of each connector at both ends of cable.

Make the cable length as short as possible to prevent noise.

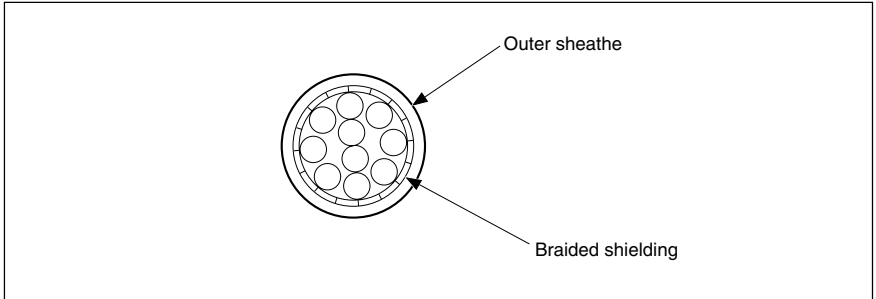

- When using a power supply with remote sensing function
Use a twisted pair with a thickness of at least 26 AWG for the output cable. The output signals use voltage-differential line driver output.
Connect the shielded wires to FG.
Set the supply voltage so that it satisfies the specified value at the interpolator input.
Recommended cables : 20276-VSV-10P × 26AWG-7/0.16 (Hirakawa Hewtech)

Reference Remote sensing function

By connecting the sensing pins (+S, -S), the voltage at point a (see the following page) is automatically maintained at the voltage value set on the power supply unit side even if the output cable is lengthened (max. 50 m). So, there is no need to take into account the voltage drop at the cable.

<Example power supply with remote sensing function> Densi Lambda NNS Series

- When using a power supply without remote sensing function
Use a twisted pair with a thickness of at least 20 AWG for the output cable.
Set the supply voltage so that it satisfies the specified value at the interpolator input.

When using a power supply with remote sensing function

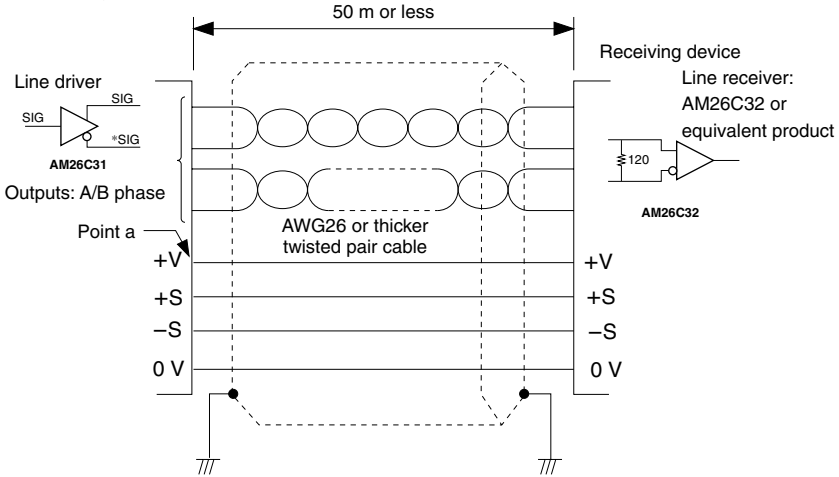

When using a power supply without remote sensing function

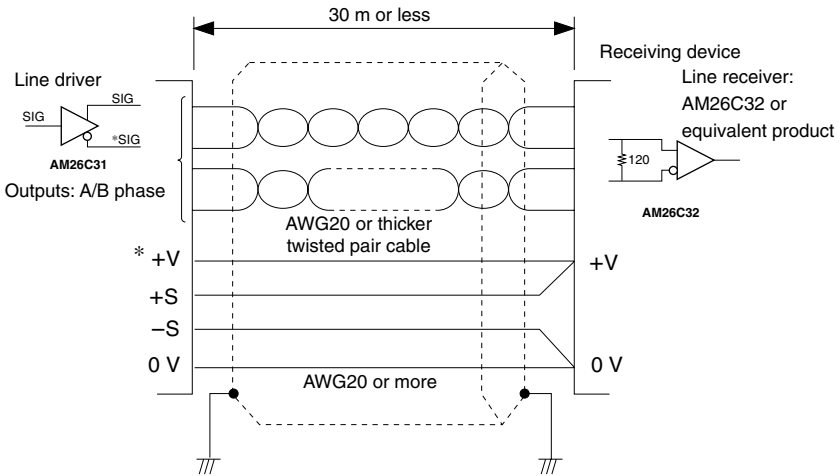

* When using DG10BNM/DG10BPM/DG10BSM/DG25BNM/DG25BPM/DG25BLM/DG25BSM, the main unit input should be at +5 V \pm 5%.

7. Outside Dimensions

Specifications and appearances of the products are subject to change without notice because of improvement.

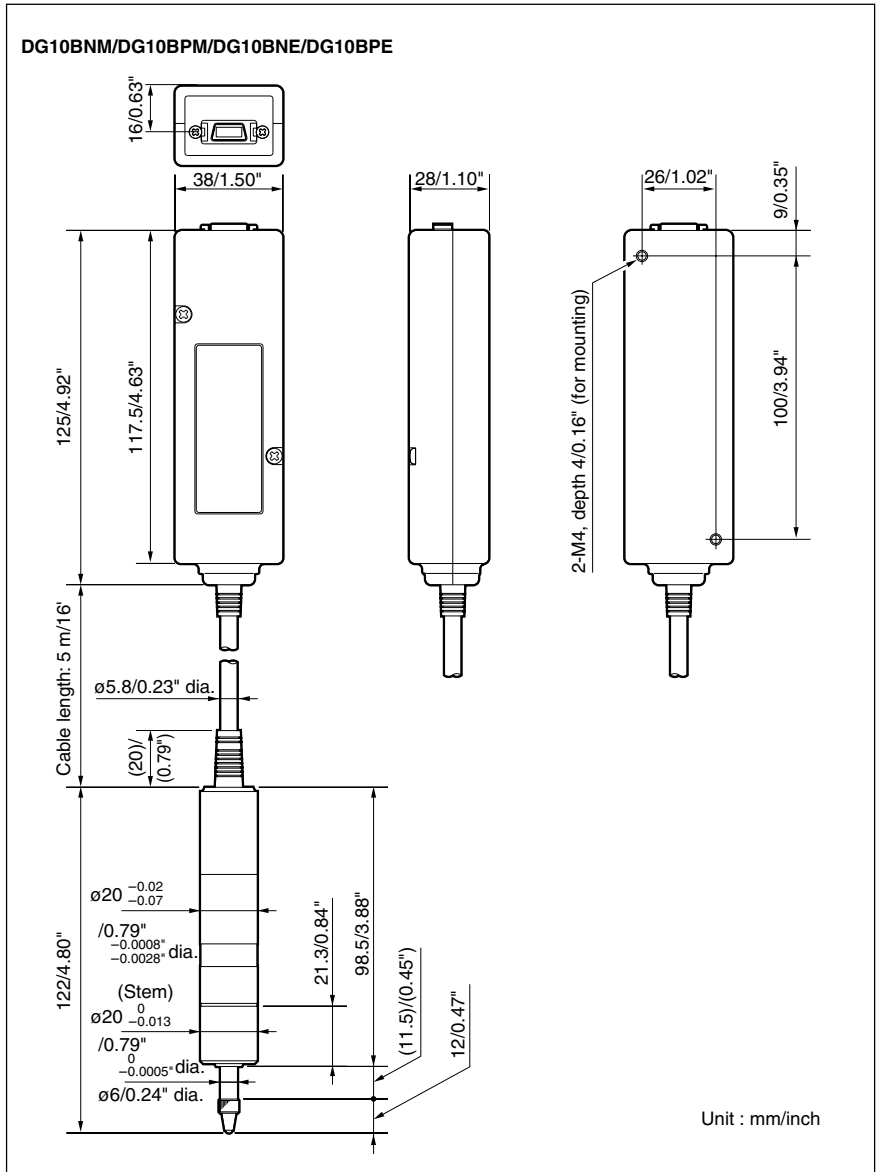

DG25BNM/DG25BPM/DG25BNE/DG25BPE

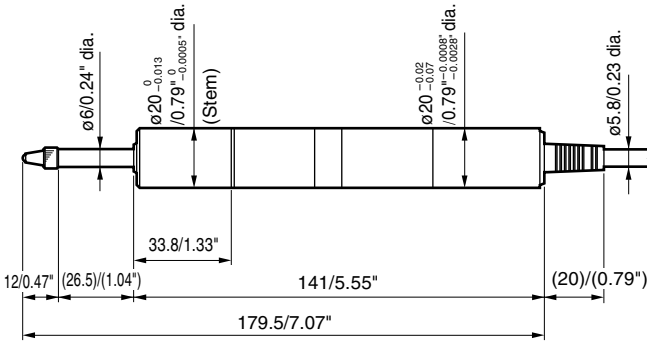

DG10BSM/DG10BSE

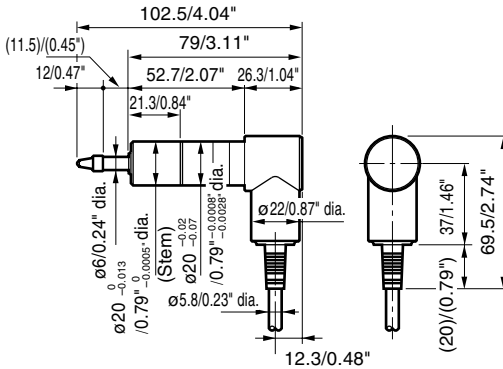

DG25BLM/DG25BSM/DG25BLE/DG25BSE

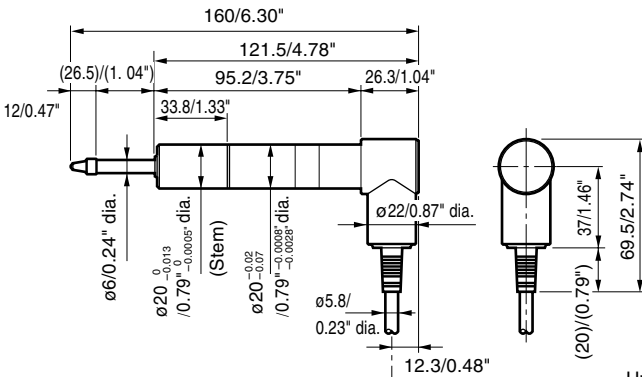

Unit : mm/inch

Roller feeler DZ-100 (Optional)

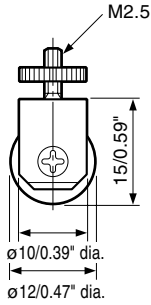

Thickness(roller): 4 mm/0.16"

Lift lever DZ-161 (Optional)

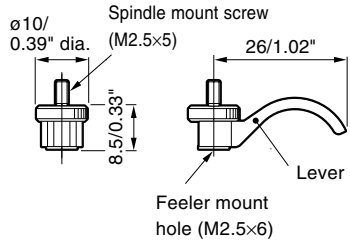

Coupling DZ-191 (Optional)

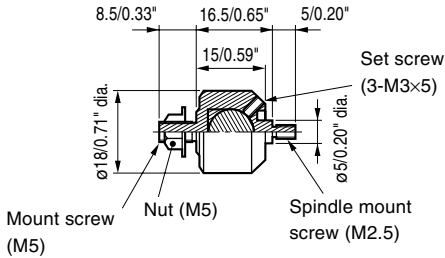

Unit : mm/inch

このマニュアルに記載されている事柄の著作権は当社にあり、説明内容は機器購入者の使用を目的としています。

したがって、当社の許可なしに無断で複製したり、説明内容（操作、保守など）と異なる目的で本マニュアルを使用することを禁止します。

The material contained in this manual consists of information that is the property of Sony Precision Technology Inc. and is intended solely for use by the purchasers of the equipment described in this manual.

Sony Precision Technology Inc. expressly prohibits the duplication of any portion of this manual or the use thereof for any purpose other than the operation or maintenance of the equipment described in this manual without the express written permission of Sony Precision Technology Inc.

Le matériel contenu dans ce manuel consiste en informations qui sont la propriété de Sony Precision Technology Inc. et sont destinées exclusivement à l'usage des acquéreurs de l'équipement décrit dans ce manuel.

Sony Precision Technology Inc. interdit formellement la copie de quelque partie que ce soit de ce manuel ou son emploi pour tout autre but que des opérations ou entretiens de l'équipement à moins d'une permission écrite de Sony Precision Technology Inc.

Die in dieser Anleitung enthaltenen Informationen sind Eigentum von Sony Precision Technology Inc. und sind ausschließlich für den Gebrauch durch den Käufer der in dieser Anleitung beschriebenen Ausrüstung bestimmt. Sony Precision Technology Inc. untersagt ausdrücklich die Vervielfältigung jeglicher Teile dieser Anleitung oder den Gebrauch derselben für irgendeinen anderen Zweck als die Bedienung oder Wartung der in dieser Anleitung beschriebenen Ausrüstung ohne ausdrückliche schriftliche Erlaubnis von Sony Precision Technology Inc.