

SONY®

デジタルゲージ / Digital Gauge / Digitale Meßtaster

DG10B / DG25B Series

DG10BN / DG10BP / DG10BS

DG25BN / DG25BP / DG25BL / DG25BS

お買い上げいただき、ありがとうございます。
ご使用前に、この取扱説明書を必ずお読みください。
ご使用に際しては、この取扱説明書どおりお使いください。
お読みになった後は、後日お役に立つこともございますので、必ず保管してください。

Read all the instructions in the manual carefully before use and strictly follow them.
Keep the manual for future references.

Lesen Sie die ganze Anleitung vor dem Betrieb aufmerksam durch und folgen Sie beim Betrieb des Geräts den Anweisungen. Bewahren Sie diese Bedienungsanleitung zum späteren Nachlesen griffbereit auf.

取扱説明書 / Instruction Manual / Bedienungsanleitung
第1版 / 1st Edition / 1.Auflage

Safety Precautions

Sony Precision Technology products are designed in full consideration of safety. However, improper handling during operation or installation is dangerous and may lead to fire, electric shock or other accidents resulting in serious injury or death. In addition, these actions may also worsen machine performance.

Therefore, be sure to observe the following safety precautions in order to prevent these types of accidents, and to read these "Safety Precautions" before operating, installing, maintaining, inspecting, repairing or otherwise working on this unit.

Warning Indication Meanings

The following indications are used throughout this manual, and their contents should be understood before reading the text.

Warning

Failure to observe these precautions may lead to fire, electric shock or other accidents resulting in serious injury or death.

Caution

Failure to observe these precautions may lead to electric shock or other accidents resulting in injury or damage to surrounding objects.

Note

This indicates precautions which should be observed to ensure proper handling of the equipment.

Warning



- Do not damage, modify, excessively bend, pull on, place heavy objects on or heat the cable, as this may damage the cable and result in fire or electric shock.



- Do not disassemble or modify the unit, as this may result in injury or electric shock. These actions may also damage the internal circuitry.

Caution



- The unit does not have an explosion-proof structure. Therefore, do not use the unit in an atmosphere charged with inflammable gases as this may result in fire.
- Do not use the unit in places where it may receive excessive shocks. Otherwise the inside of the unit may be damaged or the unit may become unable to produce normal output signals.
- Be sure to turn off the power before connecting or disconnecting connectors in order to prevent damage or misoperation.

Operating Cautions

- After mounting the probe, insert the connector in the display unit connector until it locks. Be sure to turn off the power switch before connecting or disconnecting the connector.
- Keep a strong magnetic source at least 10 cm (3.94") away from the probe (head built-in portion).
- Do not forcibly pull the cable, or it may break open.
- The probe is short circuited to the frame GND (ground terminal) of the display unit by shield wire of the cable.
When the probe is used with an other signal processing device on a machine tool, etc., be aware of the ground level.
- The N/L-type probe has an unsealed spindle for use in mechanical devices and measuring rooms having a favorable work environment. Due to the low measurement force, the N/L-type cannot be used with the spindle directed upward.
- The P/S-type probe is dust-proof, drip-proof, and oil-resistant making it suitable for use in environments subject to chips, cutting oil, and machine oils. However, avoid immersing the P/S-type probe in cutting oil, etc., as it is not of a water-proof structure.
- Adhesion of cutting oil, etc. which increases in viscosity after drying, may hinder accurate spindle motion. Remove them with water or tepid water. Then apply machine oil or the like to the spindle.
- The P/S-type probe is provided on the sliding portion of the spindle with an anti-drip/dust seal of nitrile rubber. Spindle movement may be impaired by exposure to cutting oil, water, etc. that may remove oil from the spindle surface.

Mounting Instructions

- Be sure to chuck the probe stem for mounting. If other probe portion needs to be chucked, avoid chucking the name label portion (where the head is built in) and its neighborhood (Fig. 1). If the probe is mounted on another device, ensure that the probe is free from contact with mount screws.
- When replacing the feeler, since subjecting the spindle to excessive torque may damage the internal mechanism, always replace the feeler by hand without using tools. Except when using a flat feeler, it is recommended to either attach a nominal 2.5 spring washer or use a screw lock to prevent loosening of the feeler (tightening torque reference value: 0.05-0.06 N·m).
- The probe comprises ball bearing. Therefore, chucking the probe stem too tightly when mounting may damage the spindle and prevent its smooth motion.
- **A holder of dimensions as shown in Fig. 2 may be used to mount the probe, tightening the screw to about 4 N·m torque.**
- Since mounting parallelism affects the measuring accuracy, adjust the parallelism to within 0.3 mm (0.01") in relation to 100 mm (3.94") displacement by means of mount bracket (or sleeve).
- Fix the cable in a suitable position to prevent its possible breakage. Never handle the cable by forcibly pulling or bending it. (Inside bend radius 40 mm or more)
- If the spindle is to be fixed to the machine, use coupling DZ-191 which is optionally available. Refer to the DZ-191 Instruction Manual regarding the mounting procedure.

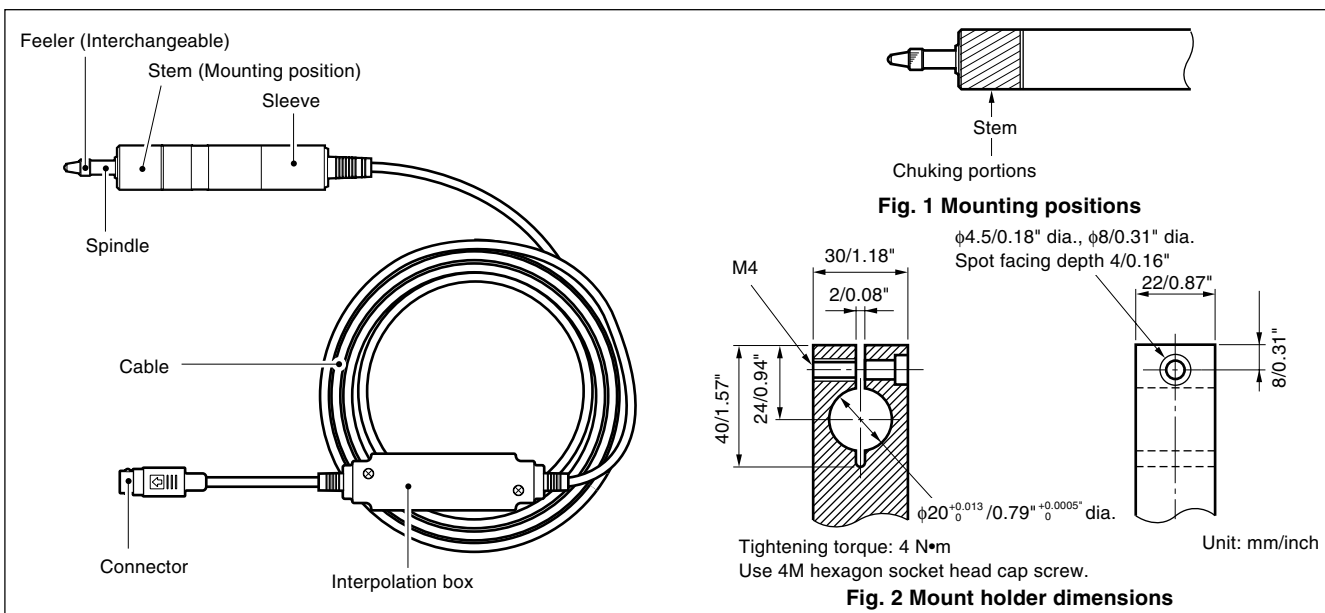

Specifications

Item \ Model	DG10BN	DG10BP	DG10BS	DG25BN	DG25BP	DG25BL	DG25BS
Measuring range	0 to 10 mm/ 0 to 0.39"			0 to 25 mm/ 0 to 0.98"			
Resolution ¹⁾	0.0005 mm						
Accuracy ²⁾	0.002 mm/ 0.00008"						
Maximum response speed	1 m/s						
Measuring force ²⁾	Upward	0.3 ±0.25 N	4.9 N or less	0.4 ±0.3 N	4.9 N or less	0.4 ±0.3 N	4.9 N or less
	Horizontal	0.6 ±0.3 N		0.7 ±0.35 N		0.7 ±0.35 N	
	Downward	0.8 ±0.35 N		1 ±0.4 N		1 ±0.4 N	
Feeler	Provided with a carbide ball tip DZ-122 (Mount screw M2.5)						
Dia. of Stem	$\phi 20 \begin{smallmatrix} 0 \\ -0.013 \end{smallmatrix}$ mm/ 0.79" $\begin{smallmatrix} 0 \\ -0.0005 \end{smallmatrix}$ " dia.						
Cable length	5 m /16'						
Operating temperature	0 °C to 50 °C /32 °F to 122 °F (Interpolation box: 0 °C to 40 °C/ 32 °F to 104 °F)						
Storage temperature	-20 °C to 60 °C /-4 °F to 140 °F						
Storage Dimensions	$\phi 20 \times 122$ mm/0.79" dia. $\times 4.80$ "	$\phi 20 \times 103$ mm/0.79" dia. $\times 4.06$ "		$\phi 20 \times 180$ mm/ 0.79" dia. $\times 7.08$ "		$\phi 20 \times 160$ mm/ 0.79" dia. $\times 6.30$ "	
Mass ³⁾	Approx. 230 g /8.11 oz			Approx. 300 g /10.58 oz			
Seal	Nil	Plovided		Nil	Plovided	Nil	Plovided

Note

- 1) As connected to LT20, LY51/LY52, LG10, LH51/LH52 or LH61.
- 2) Accuracy and measuring forces given above are those obtained at 20 °C /68 °F.
- 3) The mass indicated is the total mass excluding the cable and interpolation box.

Optional Accessories

- DZ-100 Roller feeler
- DZ-161 Lift lever
- DZ-191 Coupling
- DZ-501 Ceramic surface plate gauge stand
Surface plate: size 110×110 mm /4.33×4.33"
Mass: 13 kg /28.7 lb
- DZ-531 Large stone surface plate gauge stand
Surface plate: size 350×350 mm /13.78"×13.78"
Mass: 38 kg /83.8 lb
- DZ51 Relay adapter
This adapter unit is for connecting the DG10B/DG25B Series probe to the LY51/LY52, LG10, LH51/LH52, and LH61 display units.

■ Dimensions

Unit : mm/inch

DG10BN•BP

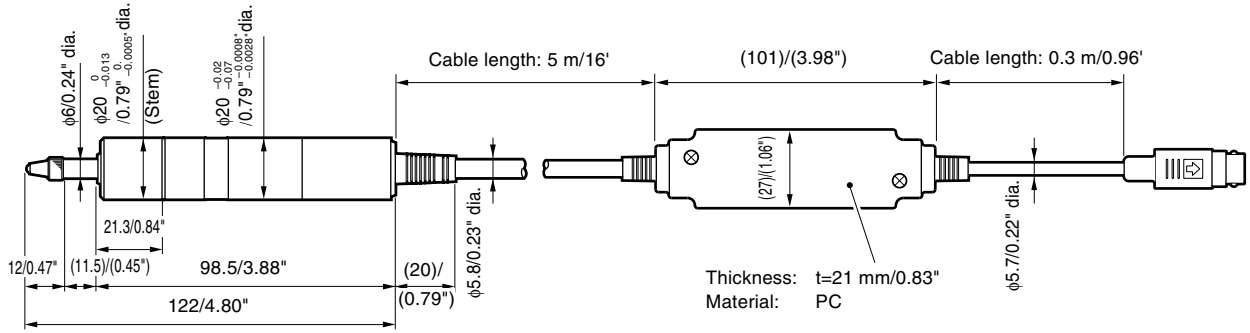

DG25BN•BP

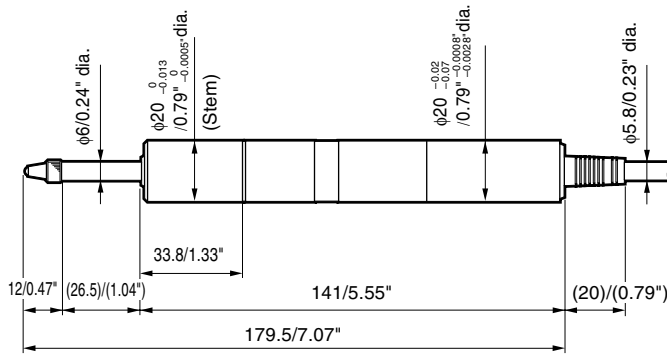

DG10BS

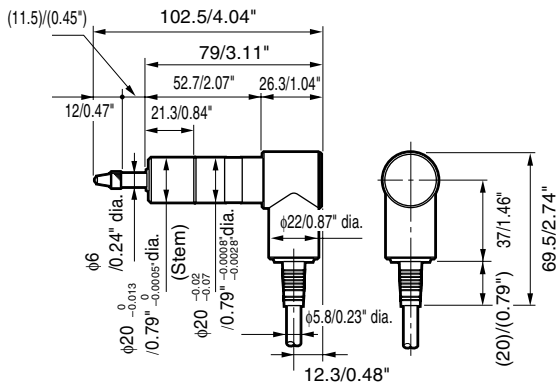

DG25BL•BS

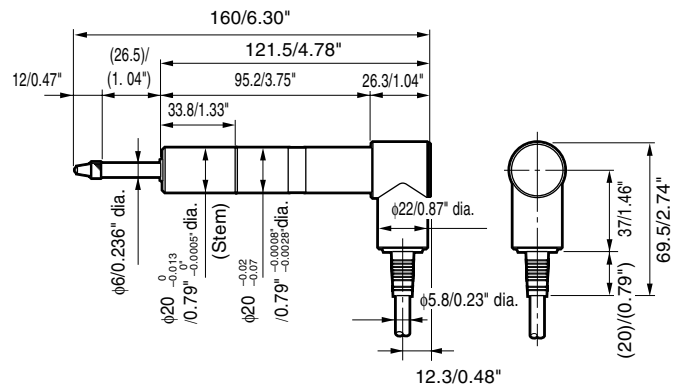

Roller feeler DZ-100 (Optional)

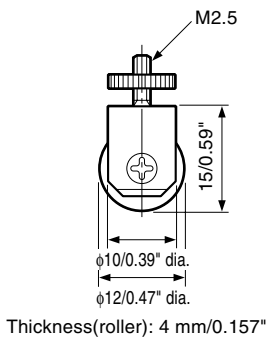

Lift lever DZ-161 (Optional)

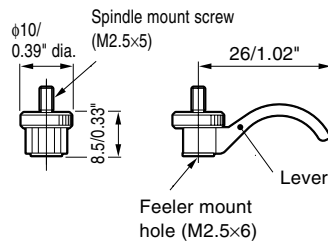

Coupling DZ-191 (Optional)

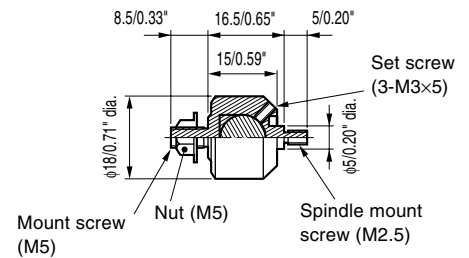

Specifications and appearances of the products are subject to change without notice because of improvement.

このマニュアルに記載されている事柄の著作権は当社にあり、説明内容は機器購入者の使用を目的としています。したがって、当社の許可なしに無断で複製したり、説明内容（操作、保守など）と異なる目的で本マニュアルを使用することを禁止します。

The material contained in this manual consists of information that is the property of Sony Precision Technology Inc. and is intended solely for use by the purchasers of the equipment described in this manual. Sony Precision Technology Inc. expressly prohibits the duplication of any portion of this manual or the use thereof for any purpose other than the operation or maintenance of the equipment described in this manual without the express written permission of Sony Precision Technology Inc.

Le matériel contenu dans ce manuel consiste en informations qui sont la propriété de Sony Precision Technology Inc. et sont destinées exclusivement à l'usage des acquéreurs de l'équipement décrit dans ce manuel.

Sony Precision Technology Inc. interdit formellement la copie de quelque partie que ce soit de ce manuel ou son emploi pour tout autre but que des opérations ou entretiens de l'équipement à moins d'une permission écrite de Sony Precision Technology Inc.

Die in dieser Anleitung enthaltenen Informationen sind Eigentum von Sony Precision Technology Inc. und sind ausschließlich für den Gebrauch durch den Käufer der in dieser Anleitung beschriebenen Ausrüstung bestimmt.

Sony Precision Technology Inc. untersagt ausdrücklich die Vervielfältigung jeglicher Teile dieser Anleitung oder den Gebrauch derselben für irgendeinen anderen Zweck als die Bedienung oder Wartung der in dieser Anleitung beschriebenen Ausrüstung ohne ausdrückliche schriftliche Erlaubnis von Sony Precision Technology Inc.